

Nidec

Power

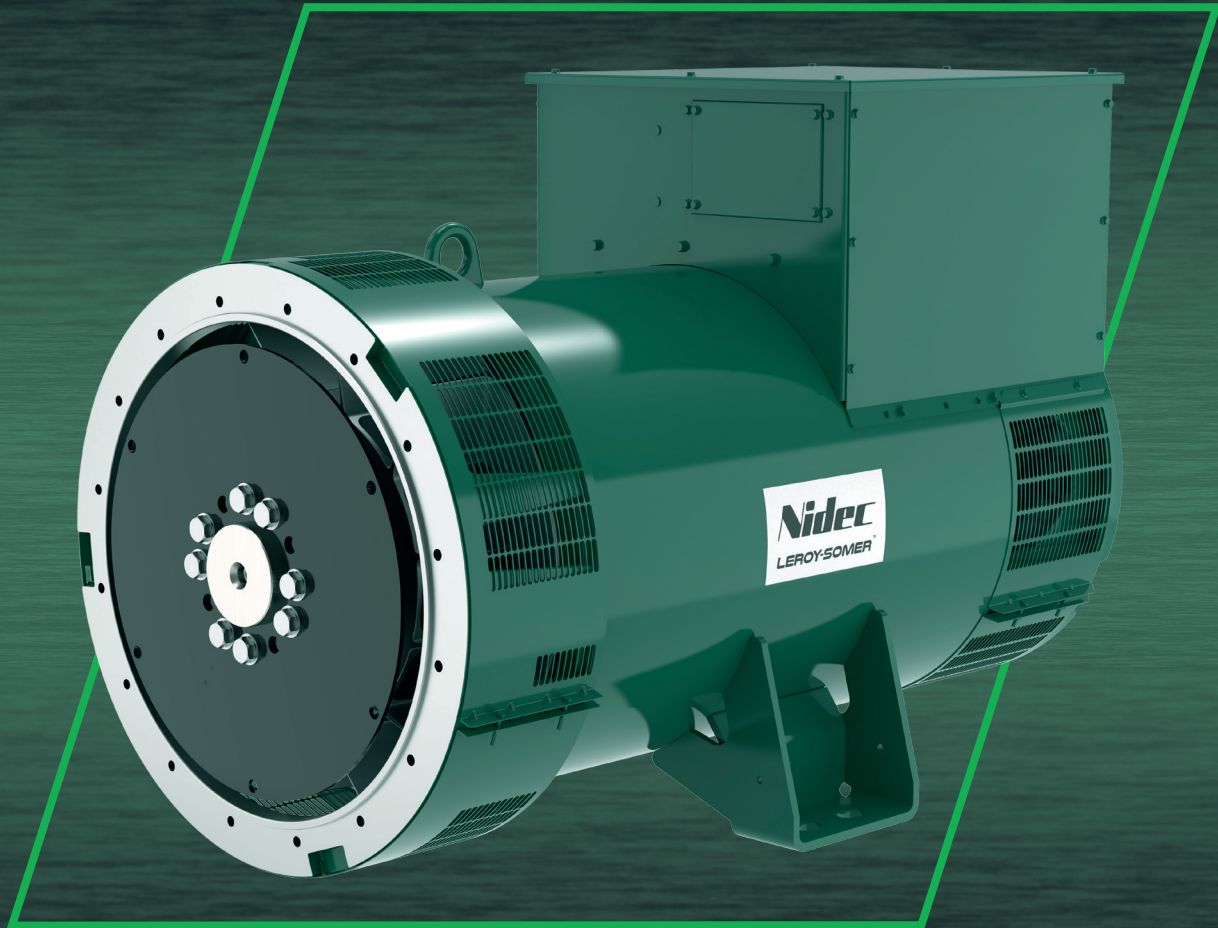

LSA 49.3

Low Voltage Alternator - 4 poles

660 to 1000 kVA - 50 Hz / 825 to 1250 kVA - 60 Hz

Electrical and mechanical data

LEROY-SOMER[™]

LSA 49.3

The best of performance

The Leroy-Somer™ LSA 49.3 alternator has been designed to offer you the best power generation performances. With its meticulous design and optimized architecture, the LSA 49.3 strikes the perfect balance between compactness, reliability, performance and longevity. Whatever your application, the Leroy-Somer™ LSA 49.3 alternator will meet your needs and will adapt to all situations.

Standards

The Leroy-Somer™ LSA 49.3 alternator meets all key international standards and regulations, including IEC 60034, NEMA MG 1.32-33, ISO 8528-3, CSA C22.2 n°100-14 and UL 1446 (UL 1004 on request). Also compliant with IEC 61000-6-2, IEC 61000-6-3, IEC 61000-6-4, VDE 0875G, VDE 0875N and EN 55011, group 1 class A for European zone. The Leroy-Somer™ LSA 49.3 alternator can be integrated in EC marked generator set, and bears EC, UKCA and CMIM markings. It is designed, manufactured and marketed in an ISO 9001 and ISO 14001 quality assurance environment.

Electrical characteristics and performances

- Class H insulation
- 2/3 pitch winding, standard 6-wire (6S) reconnectable or 12-wire (6) optional
- Voltage range:
 - 50 Hz: 220V - 240V and 380V - 415V (440V)
 - 60 Hz: 208V - 240V and 380V - 480V
- High efficiency and motor starting capacity
- Other voltages are possible with optional adapted windings:
 - 50 Hz: 440V (no. 7), 500V (no. 9), 550V (no. 22), 600V (no. 23), 690V (no. 10)
 - 60 Hz: 380V and 416V (no. 8), 600V (no. 9), 690V (no. 22)

Excitation and regulation system

Excitation system			Regulation options		
AVR	AREP	PMG (option)	C.T. Current transformer for paralleling	Mains paralleling	Remote voltage potentiometer
D350	Standard	Standard	√		√
D550	Option	Option	√	√	√

3-phase sensing is included as a standard with digital regulators.

Protection system and options

- Degree of protection: IP 23
- Complete winding protection for clean environments with relative humidity $\leq 95\%$, including indoor marine environments
- Options:
 - Filters on air inlet: derating 5%
 - Filters on air inlet and air outlet (IP 44): derating 10%
 - Reinforced winding protection for harsh environments and relative humidity greater than 95%
 - Space heater
 - Thermal protection for stator windings and shields

Mechanical construction

- Compact and rigid assembly to better withstand generator vibrations
- Steel frame
- Cast iron flanges and shields
- Two-bearing and single-bearing versions designed to be suitable for engines on the market
- Half-key balancing
- Greased for life bearings, regreasable bearings (optional)
- Standard direction of rotation: clockwise when looking at the drive end view (for anti-clockwise, derate the machine by 5%)

Terminal box design

- Easy access to the voltage regulator and to the connections
- Possible inclusion of accessories for paralleling, protection and measurement
- Connection bars for voltage reconnection

LSA 49.3 - 660 to 1000 kVA - 50 Hz / 825 to 1250 kVA - 60 Hz

General characteristics

Insulation class	H	Excitation system	AREP / PMG
Winding pitch	2/3 (wind.6S - 6-wire / wind.6 - 12-wire option)	AVR type	D350
Number of wires	6 (12 option)	Voltage regulation (*)	± 0.25%
Protection	IP 23	Short-circuit current	300% (3 IN) : 10s
Altitude	≤ 1000 m	Total Harmonic distortion THD (**)	at no load < 4% - on load < 4%
Overspeed	2250 R.P.M.	Waveform: NEMA = TIF (**)	< 50
Air flow	1 m ³ /s (50 Hz) / 1.2 m ³ /s (60 Hz)	Waveform: IEC = THF (**)	< 2%

(*) Steady state (**) Total harmonic distortion between phases, no-load or on-load (non-distorting)

Ratings 50 Hz - 1500 R.P.M.

kVA / kW - P.F. = 0.8																
Duty/T°C	Continuous duty/40°C				Continuous duty/40°C				Stand-by/40°C				Stand-by/27°C			
Class/T°K	H/125°K				F/105°K				H/150°K				H/163°K			
Phase	3 ph.				3 ph.				3 ph.				3 ph.			
Y	380V	400V	415V	440V	380V	400V	415V	440V	380V	400V	415V	440V	380V	400V	415V	440V
Δ	220V	230V	240V		220V	230V	240V		220V	230V	240V		220V	230V	240V	
YY		200V	220V			200V	220V			200V	220V			200V	220V	
LSA 49.3 S4 kVA	660	660	660	620	595	595	595	560	725	725	725	685	745	745	745	715
kW	528	528	528	496	476	476	476	448	580	580	580	548	596	596	596	572
LSA 49.3 M6 kVA	730	730	730	665	660	660	660	600	780	780	780	730	810	810	810	765
kW	584	584	584	532	528	528	528	480	624	624	624	584	648	648	648	612
LSA 49.3 M8 kVA	820	820	820	810	760	760	760	710	910	910	910	885	945	945	945	925
kW	656	656	656	648	608	608	608	568	728	728	728	708	756	756	756	740
LSA 49.3 L9 kVA	910	910	910	820	820	820	820	740	1000	1000	1000	920	1020	1020	1020	965
kW	728	728	728	656	656	656	656	592	800	800	800	736	816	816	816	772
LSA 49.3 L10 kVA	1000	1000	1000	950	900	900	900	840	1085	1085	1085	1030	1130	1130	1130	1080
kW	800	800	800	760	720	720	720	672	868	868	868	824	904	904	904	864

Ratings 60 Hz - 1800 R.P.M.

kVA / kW - P.F. = 0.8																
Duty/T°C	Continuous duty/40°C				Continuous duty/40°C				Stand-by/40°C				Stand-by/27°C			
Class/T°K	H/125°K				F/105°K				H/150°K				H/163°K			
Phase	3 ph.				3 ph.				3 ph.				3 ph.			
Y	380V	416V	440V	480V	380V	416V	440V	480V	380V	416V	440V	480V	380V	416V	440V	480V
Δ	220V	240V			220V	240V			220V	240V			220V	240V		
YY		208V	220V	240V		208V	220V	240V		208V	220V	240V		208V	220V	240V
LSA 49.3 S4 kVA	653	715	756	825	588	644	681	743	693	758	802	875	718	787	832	908
kW	522	572	605	660	470	515	545	594	554	606	642	700	574	630	666	726
LSA 49.3 M6 kVA	725	795	840	915	655	715	760	825	770	845	890	970	800	875	925	1005
kW	580	636	672	732	524	572	608	660	616	676	712	776	640	700	740	804
LSA 49.3 M8 kVA	815	890	940	1025	735	805	850	925	865	945	1000	1090	895	980	1040	1130
kW	652	712	752	820	588	644	680	740	692	756	800	872	716	784	832	904
LSA 49.3 L9 kVA	905	990	1045	1140	815	895	940	1025	960	1050	1110	1210	1000	1090	1155	1255
kW	724	792	836	912	652	716	752	820	768	840	888	968	800	872	924	1004
LSA 49.3 L10 kVA	990	1083	1146	1250	891	975	1031	1125	1049	1148	1215	1325	1089	1192	1260	1375
kW	792	866	917	1000	713	780	825	900	839	918	972	1060	871	954	1008	1100

Efficiencies 400V - 50 Hz (— P.F.: 0.8) (--- P.F.: 1)

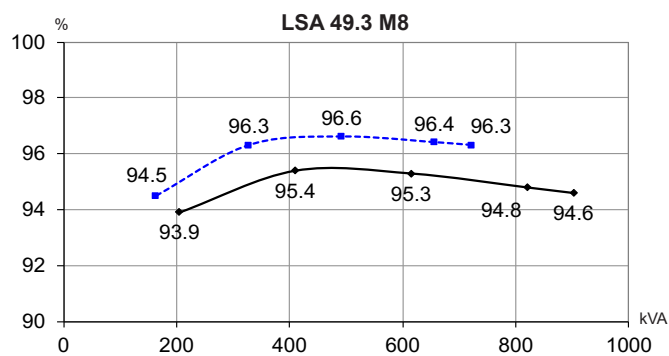
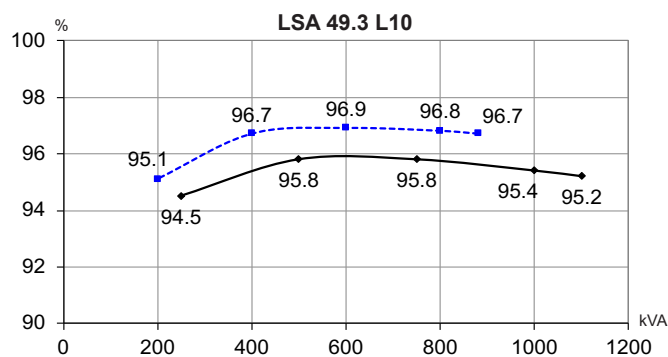
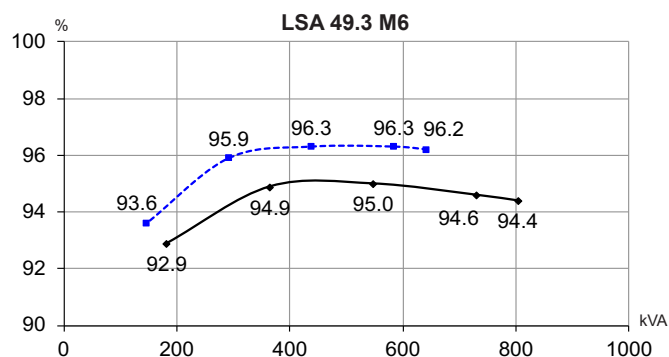
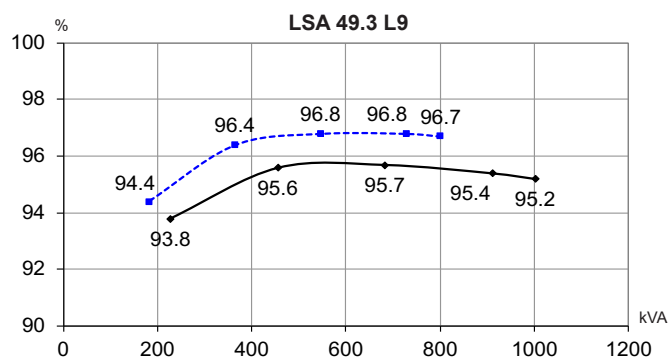
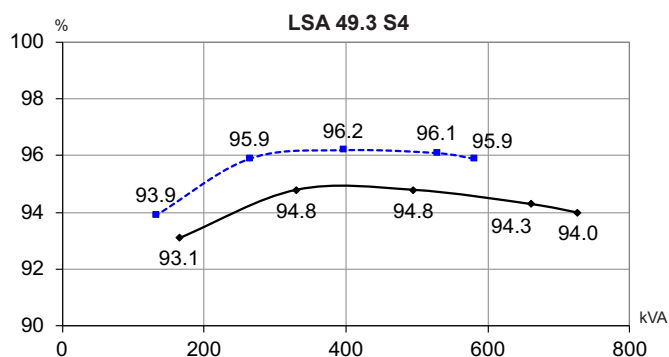

Reactances (%). Time constants (ms) - Class H / 400 V

	S4	M6	M8	L9	L10
Kcc Short-circuit ratio	0.33	0.42	0.34	0.41	0.34
Xd Direct-axis synchronous reactance unsaturated	350	294	348	303	348
Xq Quadrature-axis synchronous reactance unsaturated	178	150	177	154	177
T'do No-load transient time constant	2002	2074	2094	2138	2153
X'd Direct-axis transient reactance saturated	17.5	14.2	16.6	14.1	16.1
T'd Short-circuit transient time constant	100	100	100	100	100
X''d Direct-axis subtransient reactance saturated	14	11.3	13.3	11.3	12.9
T''d Subtransient time constant	10	10	10	10	10
X''q Quadrature-axis subtransient reactance saturated	16.3	12.8	14.9	12.4	14.1
Xo Zero sequence reactance	0.72	0.59	0.69	0.59	0.67
X2 Negative sequence reactance saturated	15.17	12.1	14.11	11.92	13.53
Ta Armature time constant	15	15	15	15	15

Other class H / 400 V data

io (A) No-load excitation current	0.99	1.11	0.87	0.99	0.9
ic (A) On-load excitation current	4.04	3.8	3.52	3.46	3.62
uc (V) On-load excitation voltage	46	43.2	39.9	39.1	40.9
ms Response time ($\Delta U = 20\%$ transient)	500	500	500	500	500
kVA Start ($\Delta U = 20\%$ cont. or 30% trans.)	1560	2050	2050	2600	2600
% Transient ΔU (on-load 4/4) - P.F.: 0.8 _{LAG}	14.4	12.6	14.2	12.2	13.6
W No-load losses	7968	9374	8753	10104	9556
W Heat dissipation	31765	32819	35599	34562	38447

Transient voltage variation 400V - 50 Hz

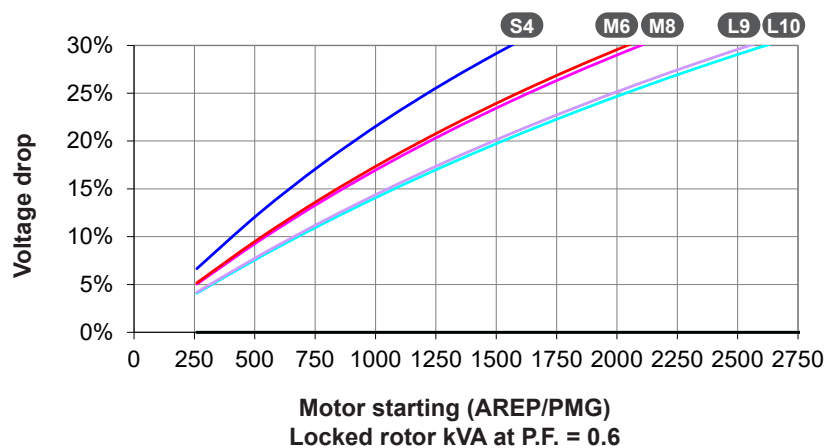
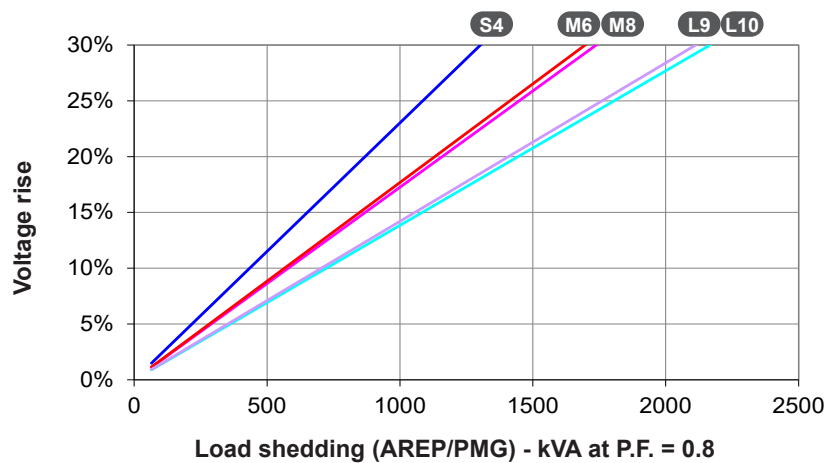
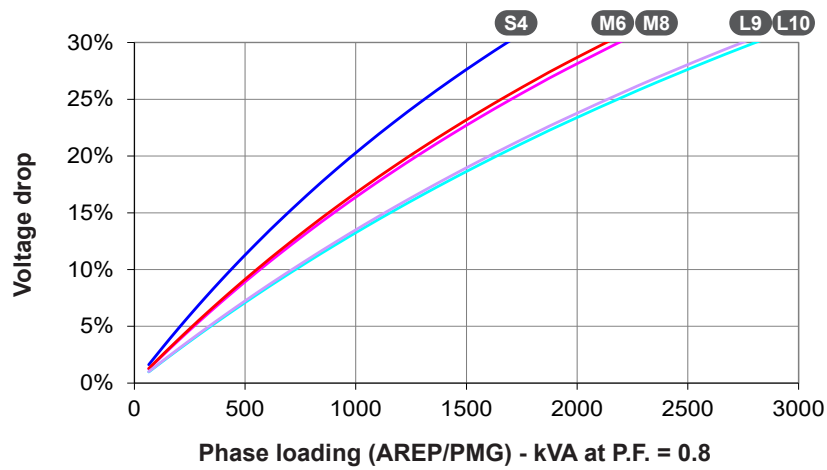

- 1) For a starting P.F. other than 0.6, the starting kVA must be multiplied by $K = \text{Sine P.F.} / 0.8$
- 2) For voltages other than 400V (Y), 230V(Δ) at 50 Hz, then kVA must be multiplied by $(400/U)^2$ or $(230/U)^2$.

Efficiencies 480V - 60 Hz (— P.F.: 0.8) (--- P.F.: 1)

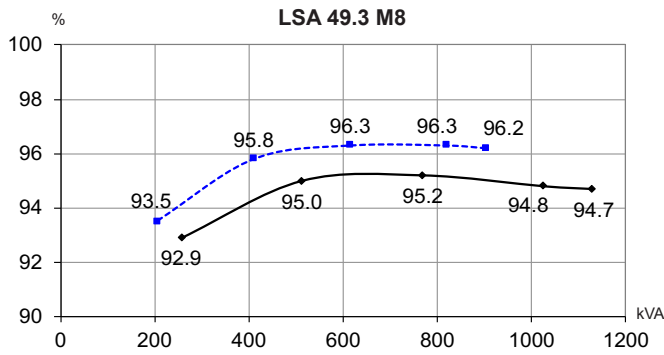
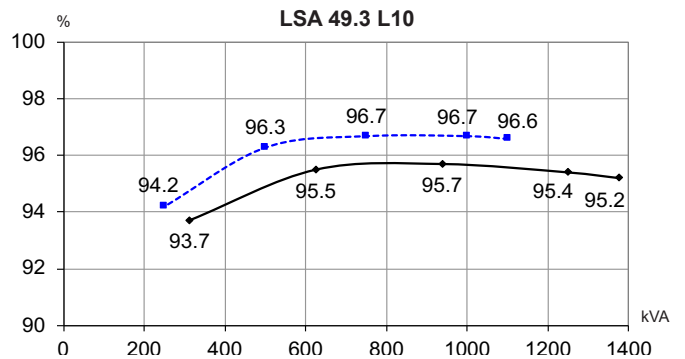
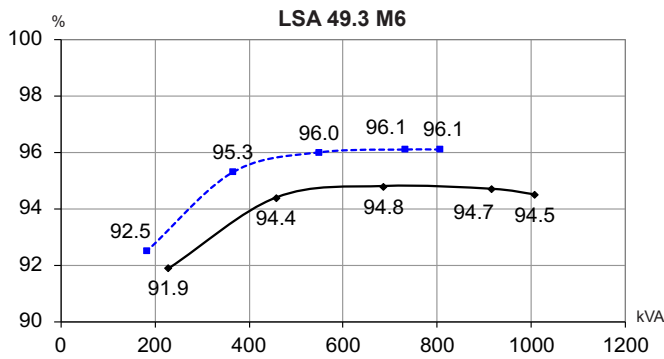
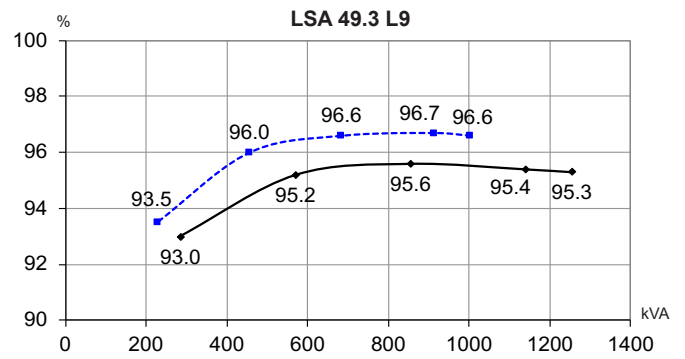
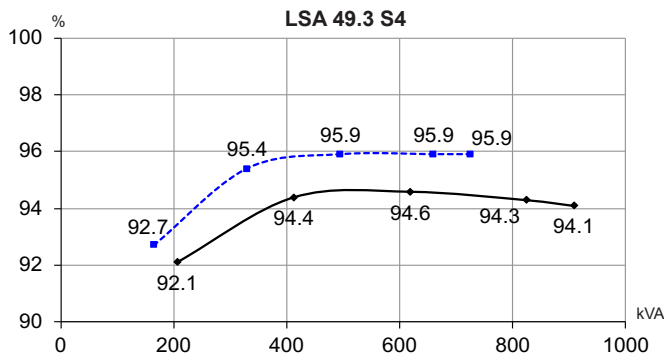

Reactances (%). Time constants (ms) - Class H / 480 V

	S4	M6	M8	L9	L10
Kcc Short-circuit ratio	0.32	0.4	0.32	0.4	0.33
Xd Direct-axis synchronous reactance unsaturated	365	307	362	317	363
Xq Quadrature-axis synchronous reactance unsaturated	186	156	185	161	185
T'do No-load transient time constant	2002	2074	2094	2138	2153
X'd Direct-axis transient reactance saturated	18.2	14.8	17.3	14.8	16.8
T'd Short-circuit transient time constant	100	100	100	100	100
X''d Direct-axis subtransient reactance saturated	14.5	11.8	13.8	11.8	13.4
T''d Subtransient time constant	10	10	10	10	10
X''q Quadrature-axis subtransient reactance saturated	17	13.4	15.5	13	14.7
Xo Zero sequence reactance	0.76	0.61	0.72	0.61	0.7
X2 Negative sequence reactance saturated	15.8	12.64	14.7	12.44	14.1
Ta Armature time constant	15	15	15	15	15

Other class H / 480 V data

	S4	M6	M8	L9	L10
io (A) No-load excitation current	0.99	1.11	0.87	0.99	0.9
ic (A) On-load excitation current	4.14	3.89	3.6	3.53	3.69
uc (V) On-load excitation voltage	47.3	44.4	41	40.2	41.9
ms Response time ($\Delta U = 20\%$ transient)	500	500	500	500	500
kVA Start ($\Delta U = 20\%$ cont. or 30% trans.)	1950	2565	2565	3250	3250
% Transient ΔU (on-load 4/4) - P.F.: 0.8 LAG	14.9	13	14.7	12.7	14
W No-load losses	12441	14387	13586	15384	14640
W Heat dissipation	39236	40967	44074	43239	47530

Transient voltage variation 480V - 60 Hz

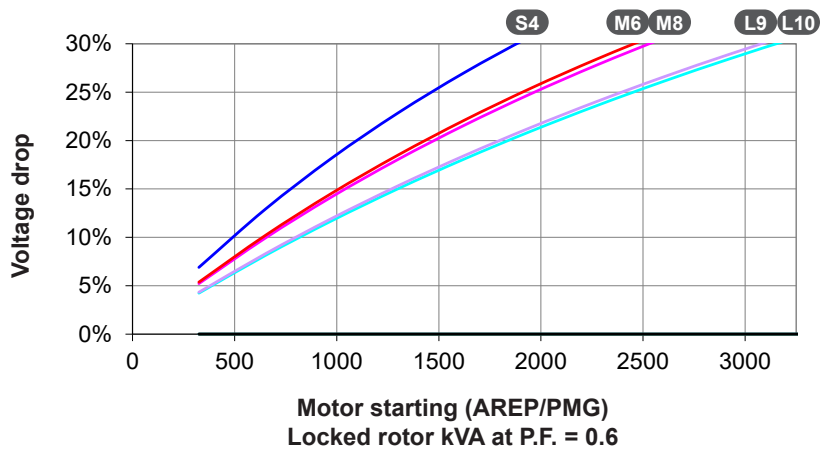
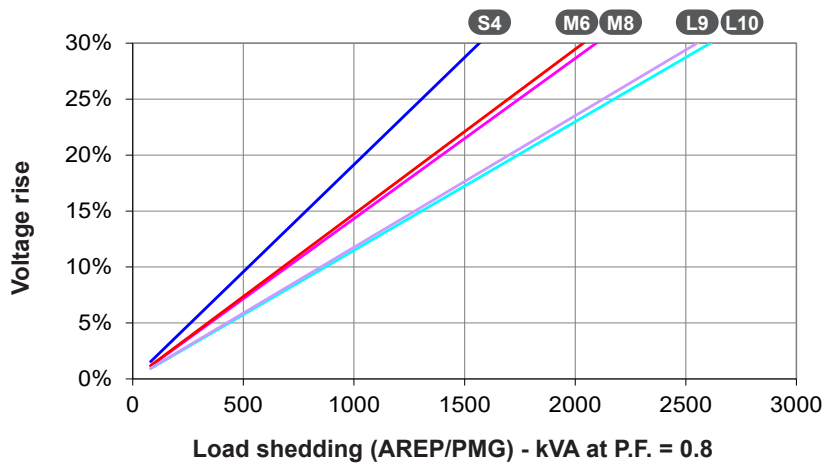
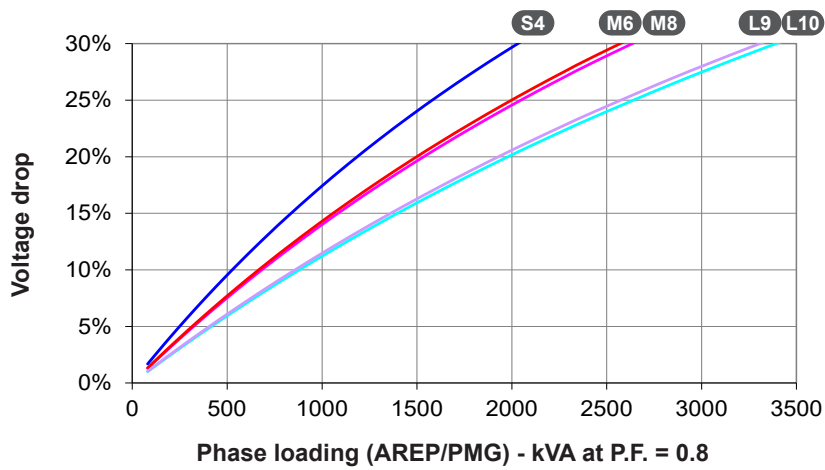

- 1) For a starting P.F. other than 0.6, the starting kVA must be multiplied by $K = \text{Sine P.F.} / 0.8$
- 2) For voltages other than 480V (Y), 277V (Δ), 240V (YY) at 60 Hz, then kVA must be multiplied by $(480/U)^2$ or $(277/U)^2$ or $(240/U)^2$.

3-phase short-circuit curves at no load and rated speed (star connection Y)

LSA 49.3 S4

Symmetrical —
Asymmetrical - - -

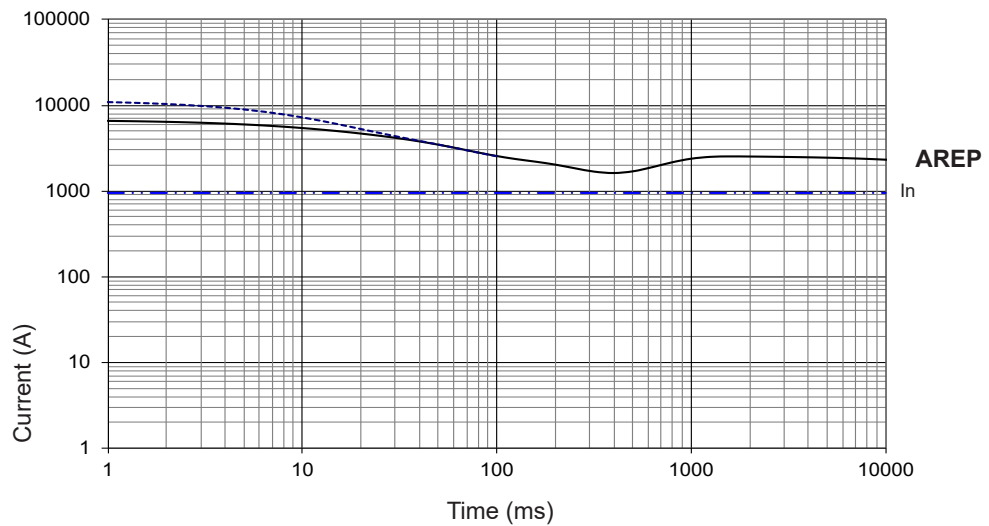

LSA 49.3 M6

Symmetrical —
Asymmetrical - - -

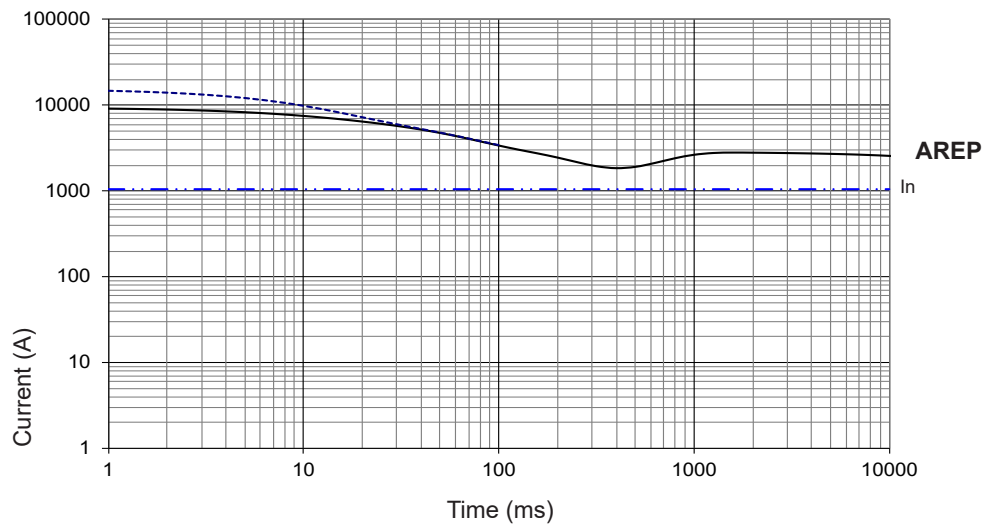

LSA 49.3 M8

Symmetrical —
Asymmetrical - - -

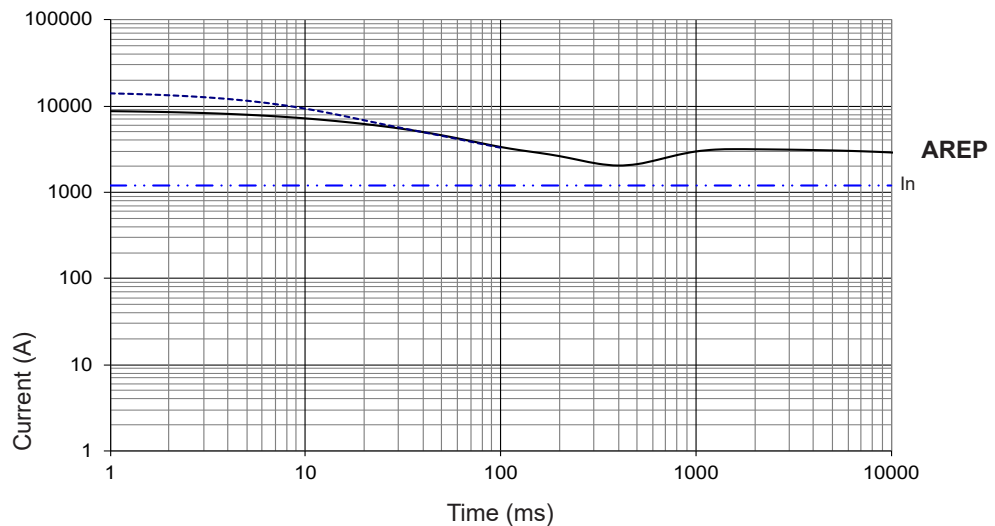

Influence due to connection

Curves shown are for star (Y) connection.

For other connections, use the following multiplication factors:

- Series delta : current value x 1.732 - Parallel star : current value x 2

3-phase short-circuit curves at no load and rated speed (star connection Y)

LSA 49.3 L9

Symmetrical —
Asymmetrical - - -

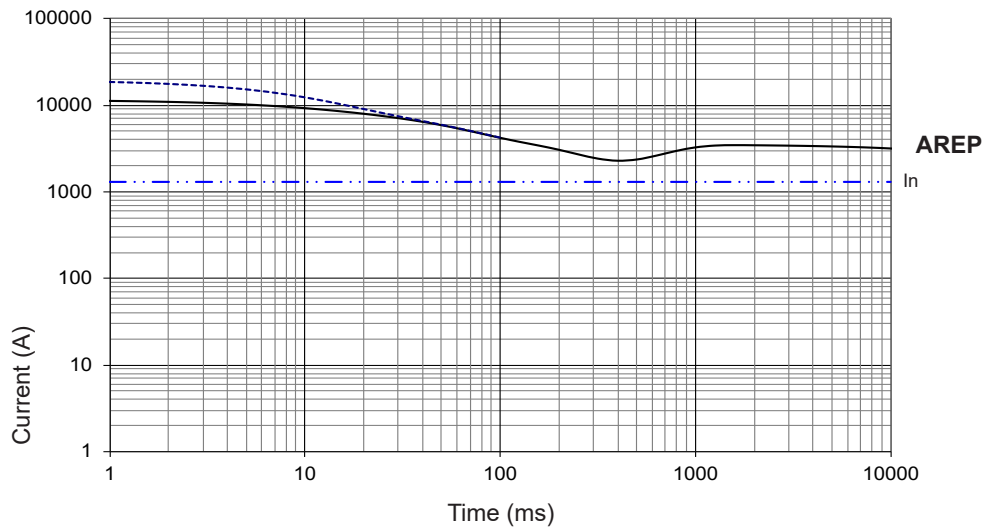

LSA 49.3 L10

Symmetrical —
Asymmetrical - - -

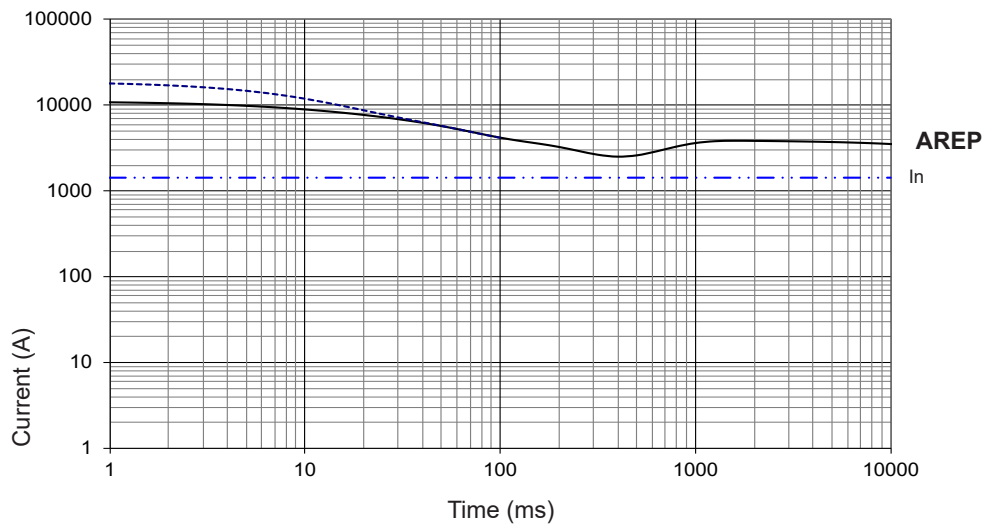

Influence due to short-circuit

Curves are based on a three-phase short-circuit.
For other types of short-circuit, use the following multiplication factors.

	3-phase	2-phase L/L	1-phase L/N
Instantaneous (max.)	1	0.87	1.3
Continuous	1	1.5	2.2
Maximum duration (AREP/PMG)	10 sec.	5 sec.	2 sec.

Single-bearing dimensions

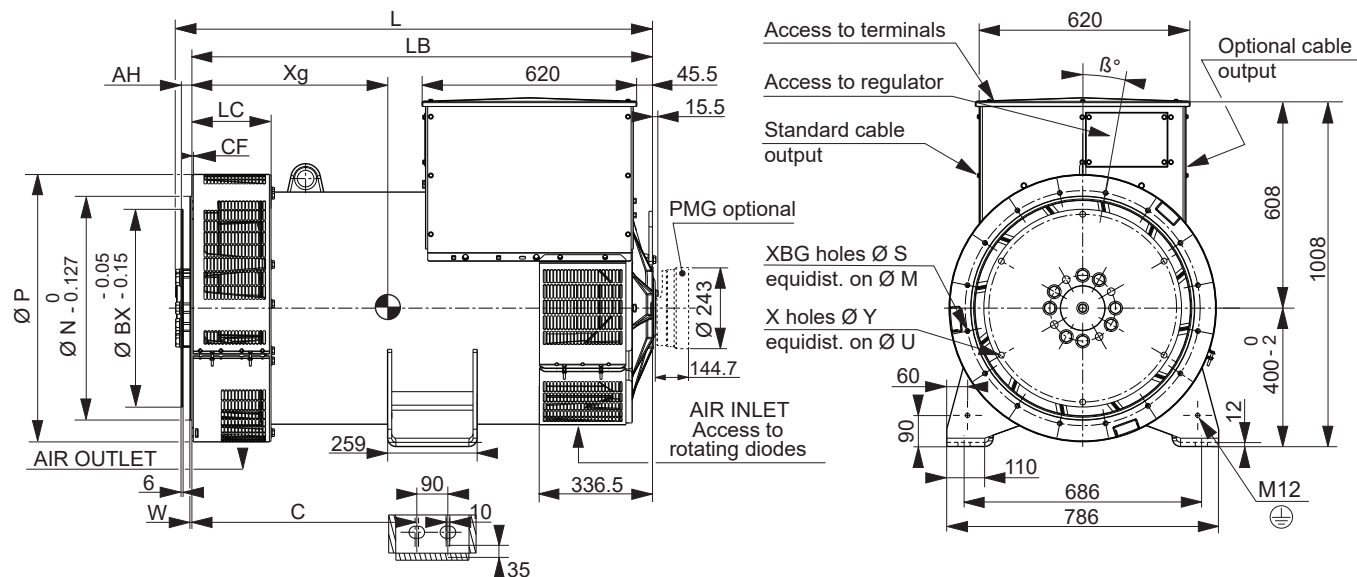

Dimensions (mm) and weight					
Type	L without PMG maxi*	LB	C	Xg	Weight (kg)
LSA 49.3 S4	1282	1241	560	590	1431
LSA 49.3 M6	1372	1331	650	629	1578
LSA 49.3 M8	1372	1331	650	636	1639
LSA 49.3 L9	1462	1421	650	673	1792
LSA 49.3 L10	1462	1421	650	681	1841

* L maxi = LB + AH maxi + 15.5

Coupling			
Flex plate	14	18	21
Flange S.A.E 1	X		
Flange S.A.E 1/2	X		
Flange S.A.E 0	X	X	
Flange S.A.E 00		X	X

Flange (mm)									
S.A.E.	P	N	M	LC	XBG	S	W	β°	CF
1	773	511.175	530.225	228.5	12	12	6	15°	38
1/2	773	584.2	619.125	228.5	12	14	6	15°	17
0	773	647.7	679.45	228.5	16	14	6	11° 15'	37
00	883	787.4	850.9	245	16	14	7	11° 15'	40

Flex plate (mm)					
S.A.E.	BX	U	X	Y	AH
14	466.7	438.15	8	14	25.4
18	571.5	542.92	6	17	15.7
21	673.1	641.35	12	18	0

Torsional analysis data

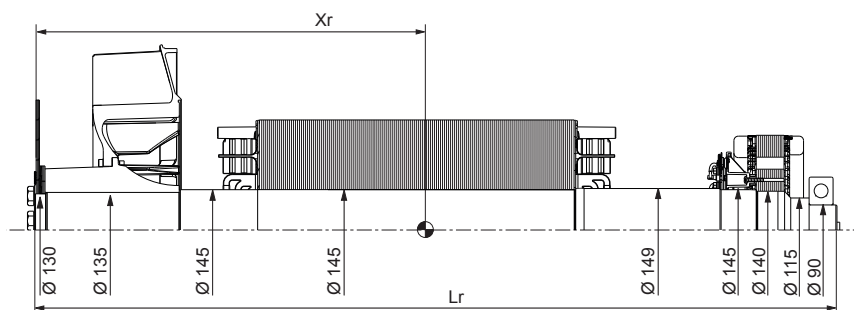

Centre of gravity: Xr (mm), Rotor length: Lr (mm), Weight: M (kg), Moment of inertia: J (kgm²): (4J = MD²)												
Flange	S.A.E. 14				S.A.E. 18				S.A.E. 21			
	Type	Xr	Lr	M	J	Xr	Lr	M	J	Xr	Lr	M
LSA 49.3 S4	585	1261	558	8.87	573	1261	560	9.13	554	1261	579	9.86
LSA 49.3 M6	625	1351	623	9.99	614	1351	625	10.25	596	1351	644	10.98
LSA 49.3 M8	634	1351	648	10.53	622	1351	650	10.79	604	1351	669	11.52
LSA 49.3 L9	671	1441	705	11.53	659	1441	707	11.79	642	1441	726	12.52
LSA 49.3 L10	679	1441	724	11.92	667	1441	726	12.18	650	1441	745	12.91

NOTE : Dimensions are for information only and may be subject to modifications. Contractual 2D drawings can be downloaded from the Nidec Power website, 3D drawing files are available upon request. The torsional analysis of the transmission is imperative. All values are available upon request.

Two-bearing dimensions

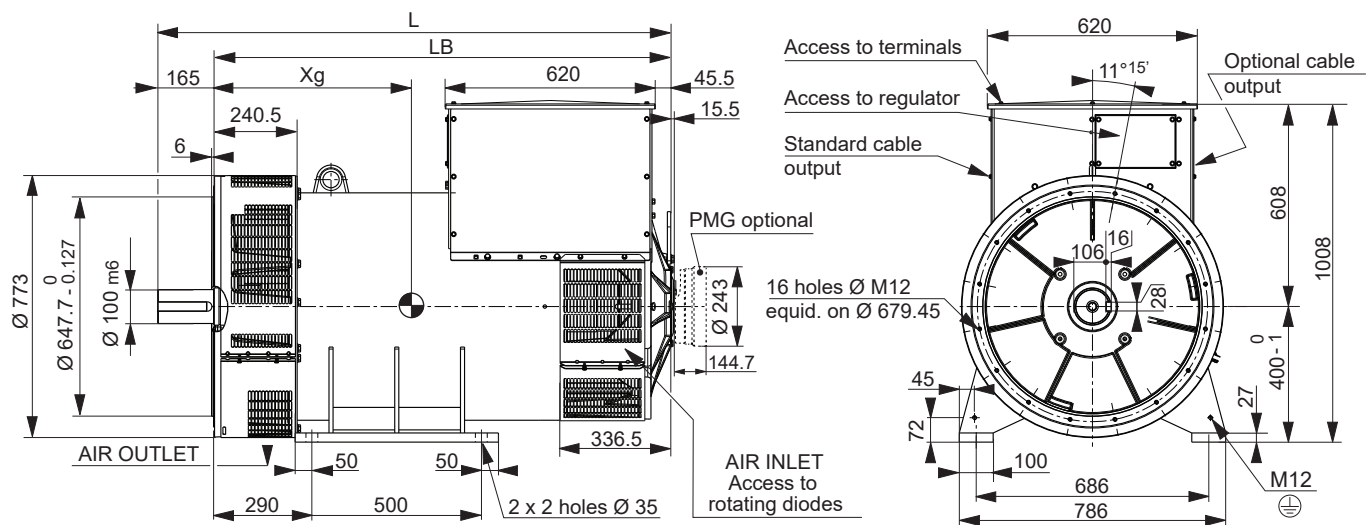

Dimensions (mm) and weight

Type	L without PMG	LB	Xg	Weight (kg)
LSA 49.3 S4	1424	1259	596	1480
LSA 49.3 M6	1514	1349	636	1622
LSA 49.3 M8	1514	1349	643	1683
LSA 49.3 L9	1604	1439	682	1835
LSA 49.3 L10	1604	1439	688	1884

Torsional analysis data

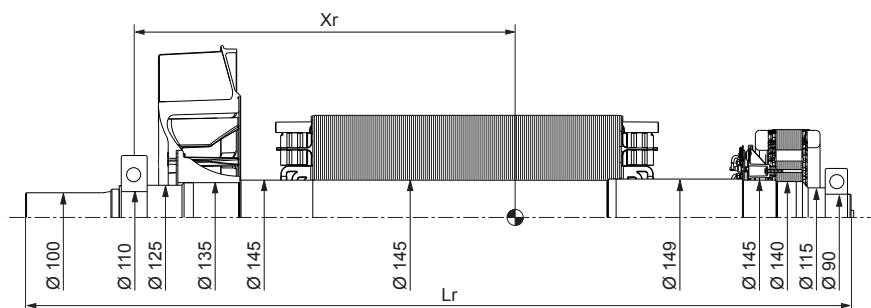

Centre of gravity: Xr (mm), Rotor length: Lr (mm), Weight: M (kg), Moment of inertia: J (kgm²): (4J = MD²)

Type	Xr	Lr	M	J
LSA 49.3 S4	559	1415	528	8.43
LSA 49.3 M6	599	1505	593	9.55
LSA 49.3 M8	607	1505	618	10.09
LSA 49.3 L9	643	1595	675	11.09
LSA 49.3 L10	651	1595	694	11.48

NOTE : Dimensions are for information only and may be subject to modifications. Contractual 2D drawings can be downloaded from the Nidec Power website, 3D drawing files are available upon request.
The torsional analysis of the transmission is imperative. All values are available upon request.



www.nidecpower.com

Connect with us at:



© 2025 Moteurs Leroy-Somer SAS. The information contained in this brochure is for guidance only and does not form part of any contract. The accuracy cannot be guaranteed as Moteurs Leroy-Somer SAS have an ongoing process of development and reserve the right to change the specification of their products without notice.

Moteurs Leroy-Somer SAS. Headquarters: Bd Marcellin Leroy, CS 10015, 16915 Angoulême Cedex 9, France. Share Capital: 32,239,235 €, RCS Angoulême 338 567 258.